

SAFETY & WARNINGS

READ AND FOLLOW ALL SAFETY INSTRUCTIONS

1. Install in accordance with national and local electrical code regulations.
2. This product is intended to be installed and serviced by a qualified, licensed electrician.
3. Do not modify or disassemble this product beyond instructions or the warranty will be void.
4. Do not use if there is any damage to the fixture or wiring. Inspect periodically.
5. Do not install near areas with exposure to salt water or chlorinated water.
6. Do not install in direct sunlight or damage to the LED phosphor will occur.
7. Do not attempt to fix this product in the field.
8. Failure to follow safety warnings, and installation instructions will void the warranty for this product.

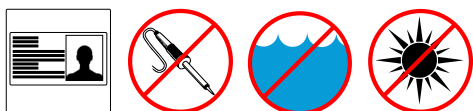

QUICK SPECS / MODELS

Input	12VDC Constant Voltage
Power	4W
Max Daisy-Chain	7 units
Ambient Temp †	-4° - 122°F (-20° - 50°C)
Environment	Damp/Indoor

† Do not install product in environment outside listed temperature.

***NOT FOR USE WITHIN POOLS OR OTHER HIGHLY CHLORINATED OR SALT WATER ENVIRONMENTS.**

REQUIRED TOOLS

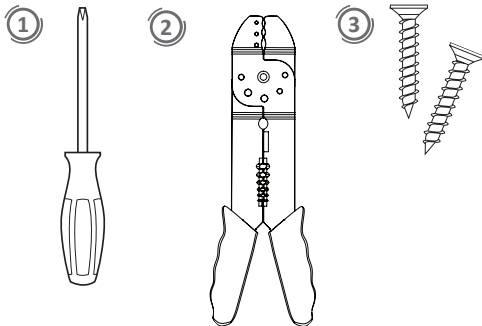

1. Phillips-head Screwdriver
2. Wire Stripper (Recommended)
3. (2) Screws per Mounting Ring

INSTALLATION

1 TURN POWER OFF AT CIRCUIT BREAKER



SHOCK HAZARD! May result in serious injury or death.

Turn power OFF at circuit breaker prior to installation.

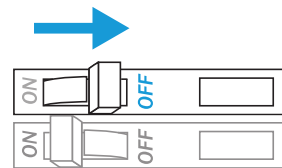

2 DETERMINE LOCATION TO INSTALL COMPONENTS

Refer to **SYSTEM DIAGRAMS**

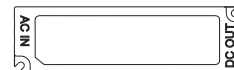

1) Class 2 Driver

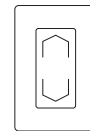

2) Control

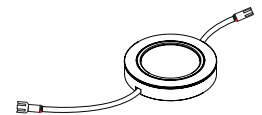

3) SPOTMOD[®] Link

WIRE GAUGE & VOLTAGE DROP

Ensure applicable wire is installed between driver, fixture, and any controls in between. When choosing wire, factor in voltage drop, amperage rating, and type (in-wall rated, wet location rated, etc.)

3 TEST CONNECTION



Prior to mounting, attach to Class 2 LED Driver, turn on power and test connection to ensure system is operating properly. Turn off power again before mounting.

INSTALLATION (CONT.)

4 MOUNT SPOTMOD® LINK

4.1 Pop SPOTMOD LINK from mounting ring.

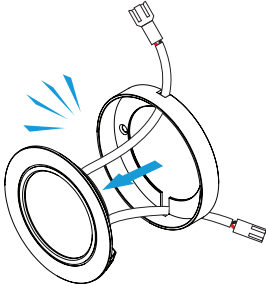

4.2 Route cords through ring, and screw mounting ring to surface.

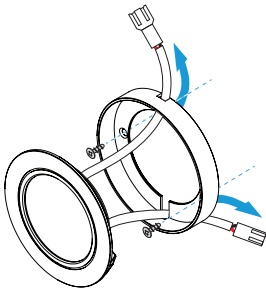

4.3 If daisy-cord is not used, tuck around puck.

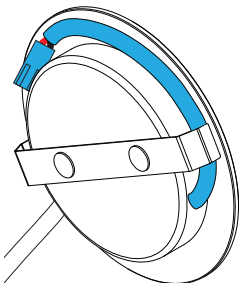

4.4 Pop puck into mounting ring.

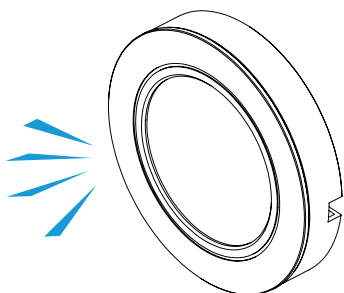

5 ATTACH DRIVER AND LIGHTING CONTROL.

Verify a compatible driver is installed. Utilize applicable wiring when installing outdoors. (Use of wet location-rated junction box recommended)

6 TURN POWER ON AT CIRCUIT BREAKER

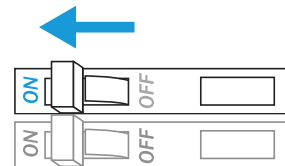

TROUBLESHOOTING

Shift in brightness and/or kelvin	<ul style="list-style-type: none"> Ensure an appropriate gauge of wire is installed between strip light and LED driver. See VOLTAGE DROP CHARTS.
Lights are flickering	<ul style="list-style-type: none"> Ensure a compatible driver and/or dimming control is installed. Check for loose connections.
Lights are turning on/off repeatedly	<ul style="list-style-type: none"> Ensure driver is not overloaded. An overloaded driver will trip the internal auto-reset (of driver) repeatedly, turning the system on/off.

TOOLS & RESOURCES

SPOTMOD® LINK SPECIFICATION SHEET
For full specifications.

SYSTEM DIAGRAMS

The following diagrams are provided as example system designs. For information regarding larger systems or systems not pictured below, please see our web page or contact technical support. Always review each component installation guide for detailed and up-to-date wiring instructions. Install in accordance with national and local electrical codes.

Traditional ON/OFF Switch System

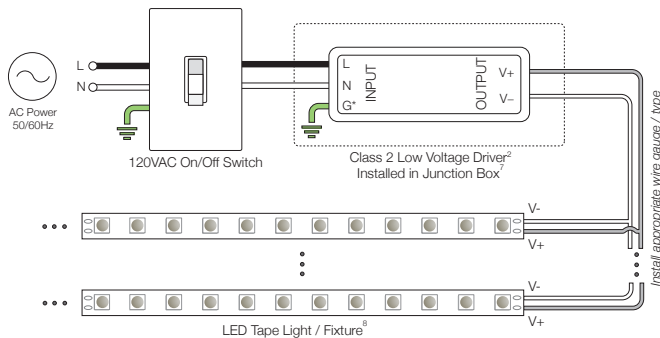

SWITCHEX® Dimmer/Driver System

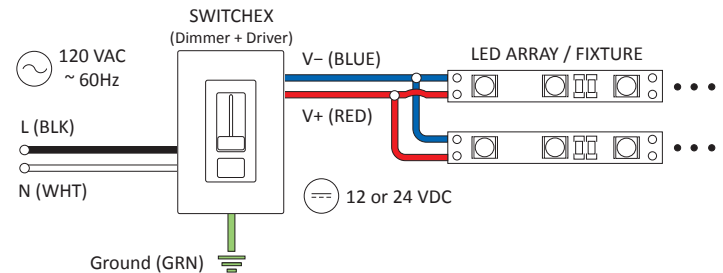

OMNIDRIVE® Electronic Dimmable Driver System

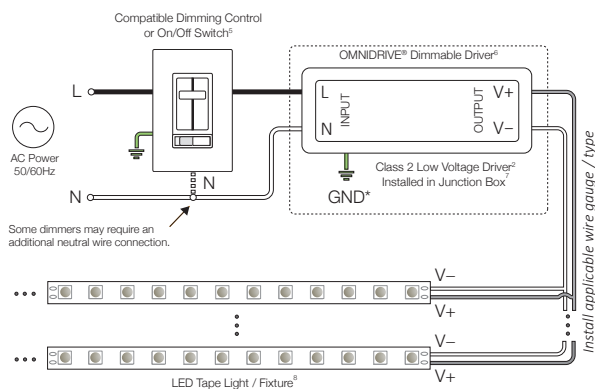

REIGN® 24V Dimmer System

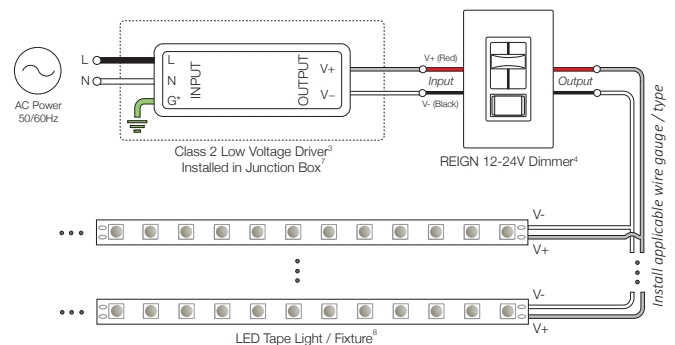

1. Driver may not require a fault ground connection. Refer to driver specifications for additional information.
2. Install a compatible Class 2 constant voltage driver. Refer to each driver specification sheet for full power ratings & load deratings.
3. Install a Class 2 constant voltage driver compatible with a low voltage PWM controller/dimmer switch. Refer to each driver specification sheet for full power ratings & load deratings.
4. Determine the number of low voltage outputs of the driver when installing multiple PWM controllers/dimmer switches. No more than one PWM controller/dimmer switch can be attached to a single output of the driver.
5. Install a compatible dimming control or switch. See the 'Electronic Dimmable Driver / Dimmer Compatibility List' for compatible dimming controls. See the dimming control manufacturer installation guide for complete wiring instructions.
6. Ensure to load the driver at least 60% of the labeled load for proper dimming performance (required for dimmable installations only).
7. Refer to driver or controller specifications for a compatible junction box.
8. See fixture specifications for maximum series run limits.

VOLTAGE DROP CHARTS

For best performance and lumen output, ensure proper wire gauge is installed to compensate for voltage drop of low voltage circuits.

12V Voltage Drop & Wire Length Distance Chart

Wire Gauge	10 W .83 A	20 W 1.7 A	30 W 2.5 A	40 W 3.3 A	50 W 2.1 A	60 W 4.2 A
20 AWG	18 ft.	9 ft.	6 ft.	5 ft.	4 ft.	3 ft.
18 AWG	34 ft.	17 ft.	11 ft.	8 ft.	6 ft.	5 ft.
16 AWG	54 ft.	27 ft.	18 ft.	13 ft.	10 ft.	9 ft.
14 AWG	86 ft.	43 ft.	29 ft.	21 ft.	17 ft.	14 ft.
12 AWG	134 ft.	68 ft.	45 ft.	34 ft.	27 ft.	22 ft.
10 AWG	199 ft.	99 ft.	66 ft.	49 ft.	39 ft.	33 ft.

Voltage Drop Chart Guide

- ① Determine load size. Let's assume load is 55 W. Round up to nearest load.
- ② Determine distance from driver to load. Let's assume the distance is 20 ft.
- ③ It's recommended to install 12 AWG to eliminate excess voltage drop.